



AUTONOMOUS DATA COLLECTOR

DATA LOGGING AT FAVORABLE PRICE - Ø 18 MM

The DCX-18 ECO is an autonomous, rechargeable battery powered instrument. It features a stainless steel 18 mm in diameter housing designed to record pressure (water depth) and temperature over long periods at a very economical price. Its small size, rechargeable battery, fully welded housing and the relative sensor option are just a few of the many advantages provided by the DCX-18 ECO.

The electronics employ the latest microprocessor technology which give high accuracy and resolution for the pressure and temperature signals. The measured values are mathematically compensated for all linearity and temperature errors of the pressure sensor.

The use of a non-volatile memory for data storage ensures high data security.

DCX-18 ECO

The sensor, electronics and the rechargeable battery are housed in a fully welded stainless steel tube for submersible deployment. For data read-out, the DCX-18 ECO must be recovered from the measurement point. The end cap, sealed by two O-Rings, must then be removed to access the serial interface.

The DCX-18 ECO works with an absolute pressure sensor. In shallow water depths where the influence of barometric pressure changes should be considered, it is recommended that a second data logger (Baro) is placed at the surface, to record the barometric pressure. The PC then calculates the differential pressure resp. the water depth by subtracting the two measured values.

DCX-18 ECO with cable (DCX-18 ECO SG or DCX-18 ECO VG)

An optional cable is available for the DCX-18 ECO, enabling data retrieval or configuration and charging the battery without removing the data logger. For relative measuring devices, the cable incorporates a capillary tube which enables venting the relative sensor.

Rechargeable Battery:

The DCX-18 ECO is charged over the USB connection with the K-104M converter connected to PC. For fast charging, connect the power supply unit or the car charging adapter to the converter. The charge status is displayed in the logger software.

DCX-18 ECO



DCX-18 ECO



DCX-18 ECO with cable

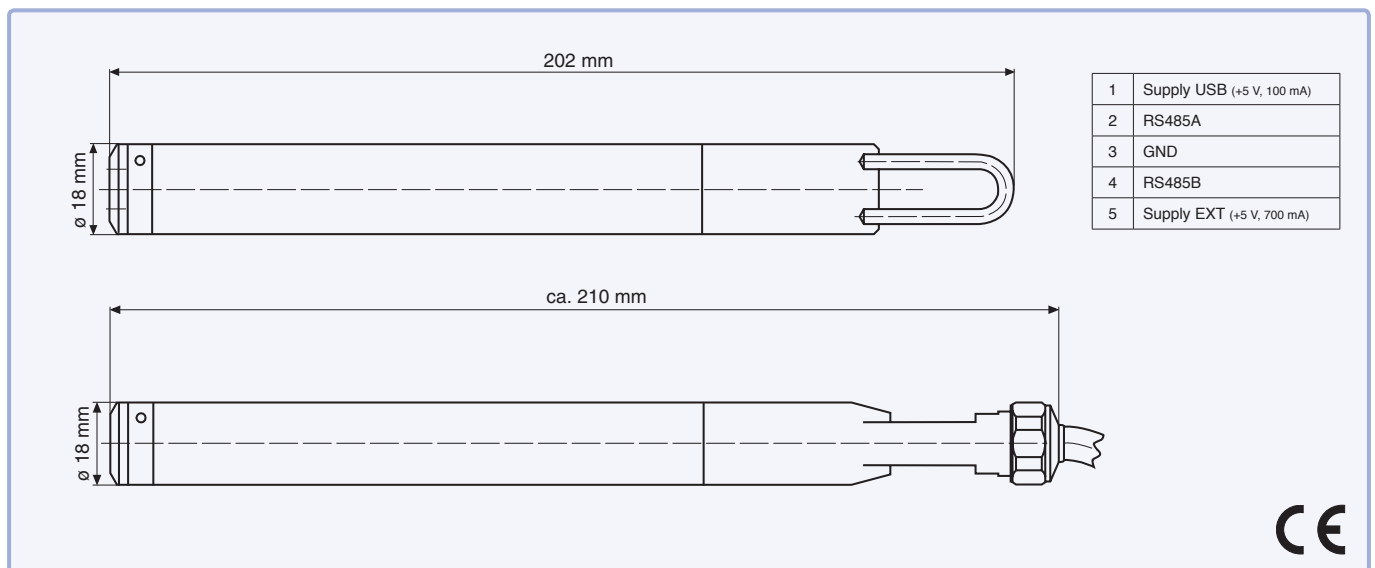



Specifications

Pressure Ranges	PAA 10 mWC (0,8...2 bar)	20 mWC (0,8...3 bar)	50 mWC (0,8...6 bar)	100 mWC (0,8...11 bar)
	PR 10 mWC (0...1 bar)	20 mWC (0...2 bar)	50 mWC (0...5 bar)	100 mWC (0...10 bar)
Overpressure	2 x Pressure Range			

PAA: Absolute. Zero at vacuum PR: Vented Gauge. Zero at atmospheric pressure

Supply	Rechargeable battery	Long Term Stability typ.	Range ≤ 2 bar: 2 mbar (0,02 mWC)
Battery Running Time *	~3 years @ 1 measurement/hour		Range > 2 bar: 0,2 %FS
Charging time ***	~7 h normal charge (USB) ~1 h fast charge (AC/DC or car adapter)	Temperature Measurement	Accuracy typ. ±1 °C
Output Interface	RS 485	Shortest Measuring Interval	1 per second
Electrical Connection	M12 / 5-pole	Memory	57'000 measuring values @ storage interval ≤ 15 s, otherwise 28'000 measuring values (always with attributed time)
Cable Option (SG/VG)	Fixed lengths: 10, 20, 50, 100 m	Material	Stainless steel AISI 316L O-Ring: Viton® Protective Cap: Delrin®
Accuracy ****	typ. 0,1 %FS	Probe Weight	≈ 150 g (without cable)
Comp. Temperature Range	-10...40 °C	Options	Other material: e.g. Hastelloy or Titanium
Error Band ** (-10...40 °C)	max. 0,2 %FS		
Resolution	max. 0,0025 %FS		

* external influences could reduce battery capacity ** Accuracy + Temperature Error *** The rechargeable battery should preferably be charged without an extension cable. It is possible to use an extension cable of up to 10 m in length for fast charging, or a cable of up to 30 m for normal charging. **** Includes Linearity + Repeatability + Hysteresis

LOGGER 5

The Logger 5 software makes it possible to configure and read autonomous KELLER data loggers. This software assists users during measurements in the field, with processing the data and also with forwarding it to partners or end customers.

Measurement data can be displayed in graphic form, exported, compensated for air pressure or converted into different units. The online function displays the current device values.

The software is included in the scope of delivery for the interface converter cables, or it can be downloaded free of charge at www.keller-druck.com.

- Supports Windows operating systems

Overview of functions: Logger 5

- Pressure and temperature channels, selectable
- Adjustable measurement interval (1s...99 days)
- Averaging with selectable number of measurements
- Recording modes:
 - continuous interval measurement
 - event-controlled recording:
 - recording starts when value is exceeded
 - recording starts when value is undercut
 - recording starts when value changes
 - combination of continuous and event-controlled recording is possible
- Adjustment of pressure zero point
- Start measurements immediately or at a set time
- Data storage: linear or ring-type memory
- Battery status display
- Online display of measuring channels
- Management of notifications and images for stations

Processing and forwarding measurement data

- Graphic display of measurement data
- Simple export of measurement data and graphics (supports Microsoft Office and these file formats: CSV-1, CSV-2, XML, Hydras, TNO, Wiski, BNA)
- Generation of measurement reports
- Station information stored in SQ Lite database

